



JS PUMP

SK Series

SK Shredder Pumps

Municipal, industrial and agricultural sewage, dairy waste, trash, garbage

The SK series runs a single or double vane tungsten carbide tip impeller against a serrated suction cover to shred and cut up solids that would clog an ordinary pump. Slide rail kits available for easier and safer pumps maintenance.

Construction Material

- Hardened ductile iron impeller and suction cover.
- Double mechanical seals.
- Class F motor insulation.
- Shaft sleeve saves on shaft wear due to abrasives and corrosion.
- Additional lip seal protection keeps impurities and abrasives away from the mechanical seals.
- Thermal overload protection guards against high amperage and high temperature.
- Enhanced cable entry sealing system.



NO.	DESCRIPTION	MATERIAL
01	STAND	FCD 400
03	NUT	SUS 304
04	WASHER	SUS 304
05	IMPELLER	FCD 400
06	KEY	SUS 304
07	PUMP HOUSING	FC 200
08	OIL CHAMBER	FC 200
08-1	ORING	NBR
09	LIP SEAL (LOWER)	NBR
11	PLUGS	SUS 304
13	MECHANICAL SEAL	SIC / CAR
14	BEARING (BOTTOM)	
16	MOTOR CASING	SUS 304
17	ROTOR SHAFT	SUS 304
18	STATOR	H-23
19	GOVERNOR SWITCH	
19B	GOVERNOR SWITCH PLATE	
20	BEARING (UP)	
21A	MOTOR BOTTOM COVER	FC 200
21A-1	ORING	NBR
21B	MOTOR UPPER COVER	FC 200
23	OVERLOAD PROTECTOR	
24	CONDENSER	
26	UPPER COVER	FC 200
26-1	ORING	NBR
27	CABLE GLAND	
27-1	GASKET	NBR
28	RUBBER SLEEVE	NBR
31	CABLE	PVC
34	HANDLE	SUS 304
37	OIL	T-32
38E	ELBOW	FC 200
38E-1	GASKET	NBR
38F	FLANGE	FC 200
38F-1	GASKET	NBR

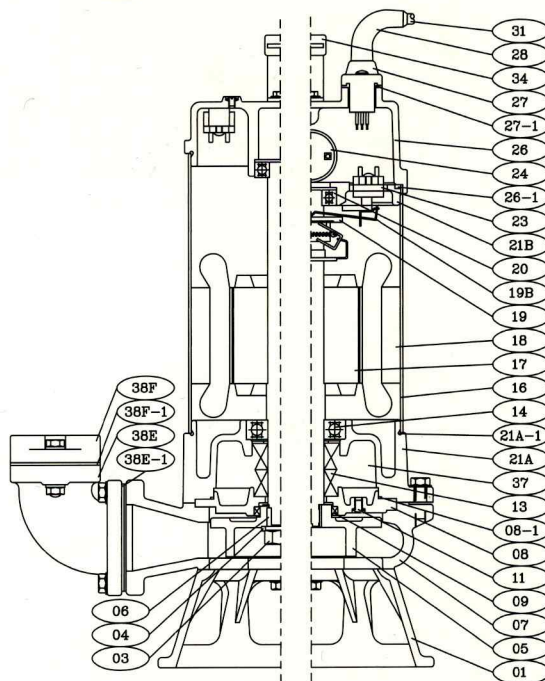
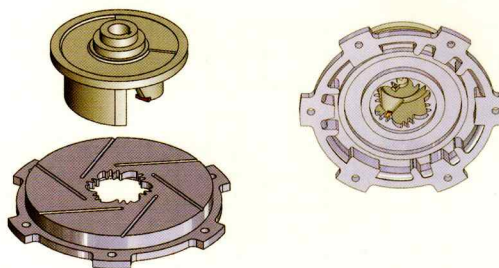

SK Performance Curve

50/60

Pump Type	Output KW	Output HP	Discharge Inch	Voltage	Max			Cable M	Weight kg
					Head M	Capacity L/min	Solid mm		
JS750SK	0.75	1	2	1 phase 100V-240V	15/15	335/335	21/21	10	29
JS1500SK	1.5	2	2		18/18	765/765	44/40	10	40
JST8SK	0.75	1	2	3 phase 200V-600V	15/15	370/370	21/21	10	28
JST15SK	1.5	2	3		17.5/17.5	955/955	44/40	10	37
JST22SK	2.2	3	3		20/20	1250/1250	44/40	10	50
JST37SK	3.7	5	3 or 4		25/25	1440/1440	35/44	10	55

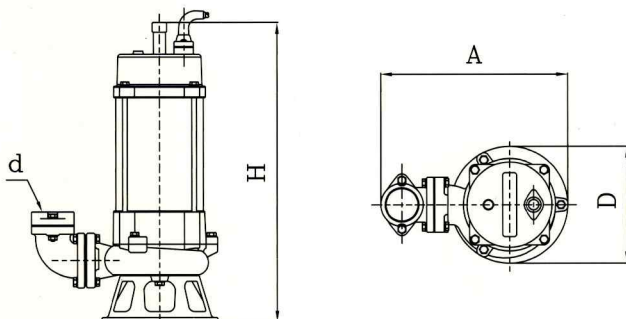
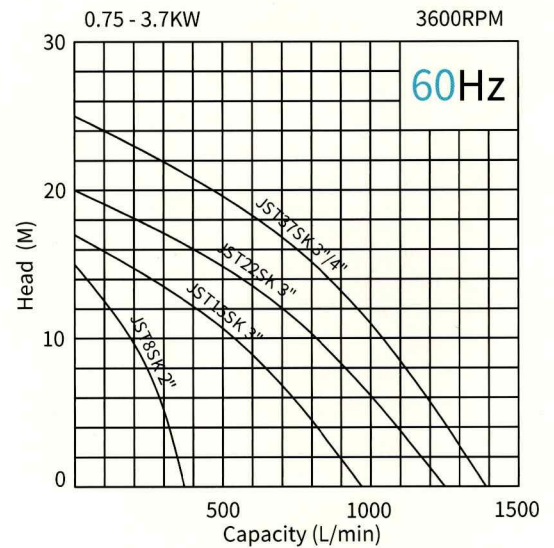
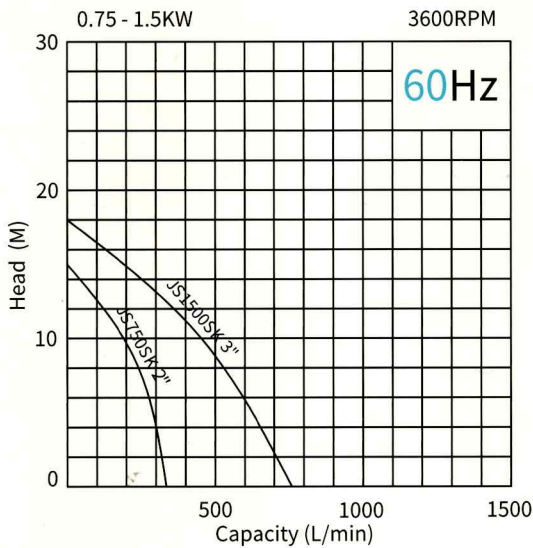
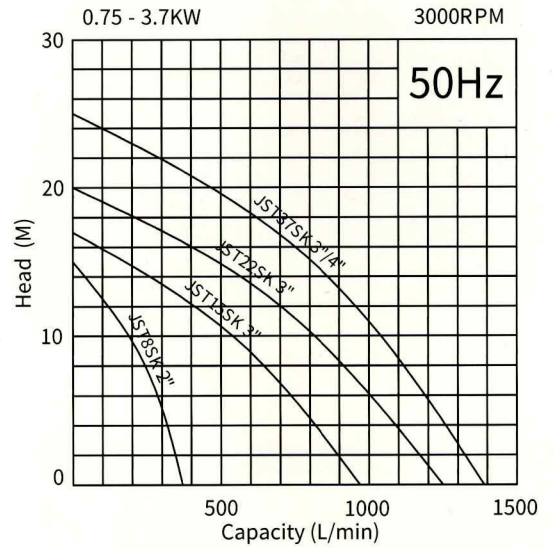
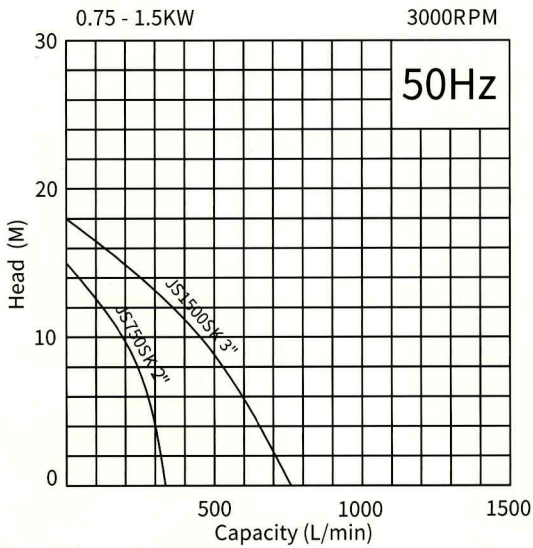

Dimensions

(mm)

PUMP TYPE	DISCHARGE BORE	PUMP SECTION		
	d	A	D	H
JS750SK	2"(50)	310	195	530
JS1500SK	3"(80)	360	240	590
JST8SK	2"(50)	310	195	465
JST15SK	3"(80)	360	240	515
JST22SK	3"(80)	400	240	560
JST37SK	3"(80)	400	245	600
JST37SK	4"(100)	450	245	600